



SPECIFICATIONS

Housing: Die formed .063" aluminum construction. Seam welded, seals housing from contamination. Mounting collar provided on surface mount for easy fixture installation (see detail). See finish note.

Reflector: .032" Aluminum. Specular aluminum (95% reflectance) Alano mirror material.

Door Frame: One piece die formed .63" aluminum with (6) captive fasteners and two stainless steel safety wires. See Finish Note.

Trunion Mount Option: 14 GA. (.074") Galvanized steel. 180° Pivot and lock into position. See finish note.

Lens: Prismatic C73 tempered glass, clear tempered glass. All lenses silicone caulked into door frame.

Ballast: OSRAM SYLVANIA QUICTRONIC® high frequency electronic ballast. Operating in a range of 120 to 277 volts 50 or 60 Hz.

Lamp: OSRAM SYLVANIA ICETRON® inductively coupled electrodeless fluorescent lamp with average rated life 100,000 hours.

Finish: Detergent cleaned with iron phosphate and chromic acid rust inhibitor. Chip resistant TGIC powder urethane polyester coating, electrostatic applied and baked. Standard color textured bronze, black or sky white. Other colors available.

Labels: ETL / CETL listed, suitable for wet location, I.B.E.W. assembled and labeled.

Fixture Warranty: The mechanics are guaranteed to be free from defective material and workmanship, under normal installation and operating conditions, for five years from date of shipment from the factory. See general terms and conditions.

Photometric Information: Contact factory or visit www.escolighting.com.

Clear tempered glass lens,
Shown with trunion mount option.



Prismatic C73 tempered glass lens,
Shown with collar mount option.



SPECIFICATIONS SUBJECT TO CHANGE WITHOUT NOTICE

ICETRON is a trademark and product of OSRAM SYLVANIA, Inc.
 SYLVANIA is a registered trademark of OSRAM SYLVANIA, Inc.

DIMENSIONAL INFORMATION

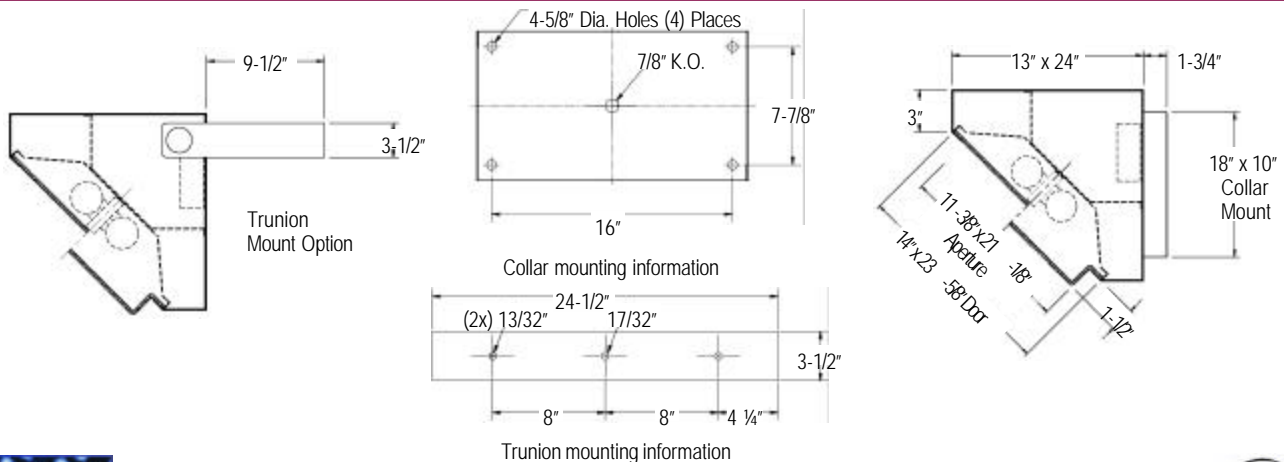

WBE City of Chicago Certified

3254 North Kilbourn Avenue Chicago, Illinois 60641-4505
 Phone: 773-427-7000 Fax: 800-217-1260 www.escolighting.com
Established 1975





HOW TO ORDER

Wall or ceiling mount	Lens	Lamp	Ballast	Color Temp	Trunion mount	Lens	Lamp	Ballast	Color Temp
SCRiS0435	Clear Tempered glass lens	ICE/100W	ICE/100W	3500K	SCRiT0435	Clear Tempered glass lens	ICE/100W	ICE/100W	3500K
SCRiS1435	Tempered prismatic lens	ICE/100W	ICE/100W	3500K	SCRiT1435	Tempered prismatic lens	ICE/100W	ICE/100W	3500K
SCRiS0535	Clear Tempered glass lens	ICE/100W	ICE/150W	3500K	SCRiT0535	Clear Tempered glass lens	ICE/100W	ICE/150W	3500K
SCRiS1535	Tempered prismatic lens	ICE/100W	ICE/150W	3500K	SCRiT1535	Tempered prismatic lens	ICE/100W	ICE/150W	3500K
SCRiS0635	Clear Tempered glass lens	ICE/150W	ICE/150W	3500K	SCRiT0635	Clear Tempered glass lens	ICE/150W	ICE/150W	3500K
SCRiS1635	Tempered prismatic lens	ICE/150W	ICE/150W	3500K	SCRiT1635	Tempered prismatic lens	ICE/150W	ICE/150W	3500K
SCRiS0441	Clear Tempered glass lens	ICE/100W	ICE/100W	4100K	SCRiT0441	Clear Tempered glass lens	ICE/100W	ICE/100W	4100K
SCRiS1441	Tempered prismatic lens	ICE/100W	ICE/100W	4100K	SCRiT1441	Tempered prismatic lens	ICE/100W	ICE/100W	4100K
SCRiS0541	Clear Tempered glass lens	ICE/100W	ICE/150W	4100K	SCRiT0541	Clear Tempered glass lens	ICE/100W	ICE/150W	4100K
SCRiS1541	Tempered prismatic lens	ICE/100W	ICE/150W	4100K	SCRiT1541	Tempered prismatic lens	ICE/100W	ICE/150W	4100K
SCRiS0641	Clear Tempered glass lens	ICE/150W	ICE/150W	4100K	SCRiT0641	Clear Tempered glass lens	ICE/150W	ICE/150W	4100K
SCRiS1641	Tempered prismatic lens	ICE/150W	ICE/150W	4100K	SCRiT1641	Tempered prismatic lens	ICE/150W	ICE/150W	4100K
SCRiS0450	Clear Tempered glass lens	ICE/100W	ICE/100W	5000K	SCRiT0450	Clear Tempered glass lens	ICE/100W	ICE/100W	5000K
SCRiS1450	Tempered prismatic lens	ICE/100W	ICE/100W	5000K	SCRiT1450	Tempered prismatic lens	ICE/100W	ICE/100W	5000K
SCRiS0550	Clear Tempered glass lens	ICE/100W	ICE/150W	5000K	SCRiT0550	Clear Tempered glass lens	ICE/100W	ICE/150W	5000K
SCRiS1550	Tempered prismatic lens	ICE/100W	ICE/150W	5000K	SCRiT1550	Tempered prismatic lens	ICE/100W	ICE/150W	5000K
SCRiS0650	Clear Tempered glass lens	ICE/150W	ICE/150W	5000K	SCRiT0650	Clear Tempered glass lens	ICE/150W	ICE/150W	5000K
SCRiS1650	Tempered prismatic lens	ICE/150W	ICE/150W	5000K	SCRiT1650	Tempered prismatic lens	ICE/150W	ICE/150W	5000K

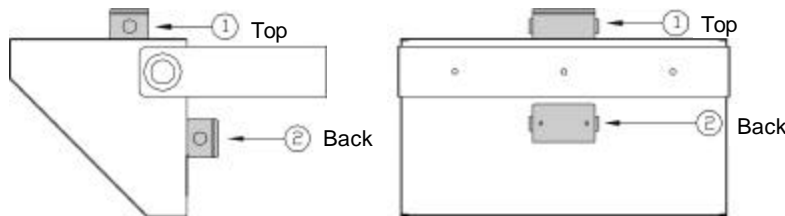

When ordering the trunion mount specify junction box location (1, or 2) and threaded hub size (1/2", 3/4" or 1").

EXAMPLE: SCRiT0435BL=Trunion mount, clear lens, 100W ICETRON® lamp and ballast, 3500K, textured black.



WBE City of Chicago Certified

3254 North Kilbourn Avenue Chicago, Illinois 60641-4505
Phone: 773-427-7000 Fax: 800-217-1260 www.escolighting.com
Established 1975

