



SPECIFICATIONS

Housing: .125" thick aluminum die formed and welded construction. See finish note.

Door Frame: .125" thick aluminum one piece die formed, with rotary action stainless steel latches. See Finish.

Lens: .0125" thick white polycarbonate lens, artwork made to order.

Ballast: SYLVANIA QUICTRONIC® or Phillips QL induction high frequency electronic ballast. See ordering information.

Lamp: SYLVANIA ICETRON® lamp from OSRAM SYLVANIA or Phillips QL Inductively coupled electrodeless fluorescent lamp with average rated life 100,000 hours. See ordering information.

Mounting: Shown with standard threaded mounting flange for 1-3/4" O.D. pipe connection. Other mounting systems available.

Finish: Detergent cleaned with iron phosphate and chromic acid rust inhibitor. Chip resistant TGIC powder urethane polyester coating, electrostatic applied and baked.

Labels: ETL, CETL listed suitable for wet location. I.B.E.W. labeled.

Fixture Warranty: The mechanics are guaranteed to be free from defective material and workmanship, under normal installation and operating conditions, for five years from date of shipment from the factory. All induction system components are warranted by the original manufacturer of the induction lighting system components, and subject to that manufacturer's warranty.

Photometric Information: Contact factory.

SPECIFICATIONS SUBJECT TO CHANGE WITHOUT NOTICE



Application: Ideal for traffic and pole mounted store signs.

ICETRON is a trademark and product of OSRAM SYLVANIA, Inc.
 QUICTRONIC is a registered trademark of OSRAM GmbH, used under license.
 SYLVANIA is a registered trademark of OSRAM SYLVANIA, Inc.

DIMENSIONS

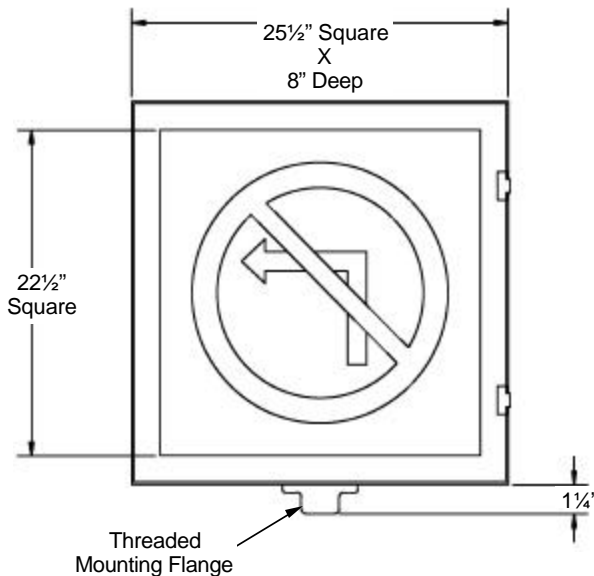

HOW TO ORDER

Cat. No.	Lamp	Ballast	Color Temp	Voltage Range	Lamp Lumens
TCSI541	ICE/150W	ICE/150W	4100K	120V—277V	12000
TCSQ930	QL/165W	QL/165W	4000K	200V—277V	12000



WBE City of Chicago Certified

3254 North Kilbourn Avenue Chicago, Illinois 60641-4505
 Phone: 773-427-7000 Fax: 800-217-1260 www.escolighting.com
 Established 1975

